

Customer	Sample
Project	Sample Project
Project Reference	12345-R1
Date and Engineer	18/02/2009 PRE/SM

Tentec[®]
www.tentec.net
 Guns Lane, West Bromwich,
 West Midlands, B70 9HS,
 United Kingdom.
 Tel: +44(0)1215241990
 Fax: +44(0)1215251999
 email: sales@tentec.net
 Internet: www.tentec.net



Bolt Tensioning Datasheet	
Flange	4 x 2500 ANSI
Ident	4" Rigid Spooler to Rigid Sp
Specification	ANSI B16.5 & MSS-SP44

Joint Information **Proposed Tensioning Tool**

Nom Thread Size	1.1/2"-8UN	Flange Configuration		
TPI	8	F1	76.2	WN
Num Bolts	8	Gap	10	
Bolt to Tensioning Ratio	100%	F2	142	SW
Load Transfer Factor LTF	1.1770	Ws		
Clamp Length	8.984	In	228.20	mm

Tensioning Tool Information				
Proposed Tensioning Tool	C10-03	RN	STD SPLIT NUT	
Tool Pressure Area	7.099	In ²	4579.90	mm ²

Bolt Information				
Bolt Material	BS:4882 - L7m			
Bolt Yield Strength	79770	lb/in ²	550	N/mm ²
Tensile Stress Area	1.502	In ²	968.79	mm ²
Bolt Length	18.20	In	462.3	mm
Torque Information				
Torque	1626	ft.lb	2205	N.m
Coefficient of Friction	0.12			

Tensioner Ident C10 - 03

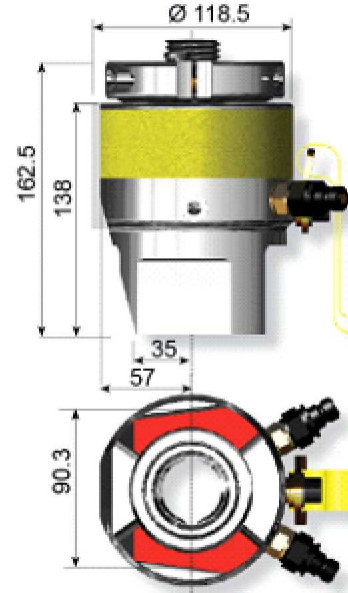

-	Bolt Stress		Bolt Load		% of Bolt Yield
	lbs/in ²	N/mm ²	Tons	kN	%
Based on Tensile Stress Area					
T1 @ A Pressure					
T1 @ B Pressure	64735	446.33	43.40	432.40	81.2
T2 Residual	55000	379.21	36.87	367.38	68.9
Max Detensioning Pressures					
Tensioning Pressures	1st Pass		2nd Pass		% of Bolt Yield
	psi	Bar	psi	Bar	%
100% Tensioning Pressures	13693	944	-	-	81.2
50% Tensioning Pressures					
Max Detensioning Pressures					

Predicted Bolt Stress Path

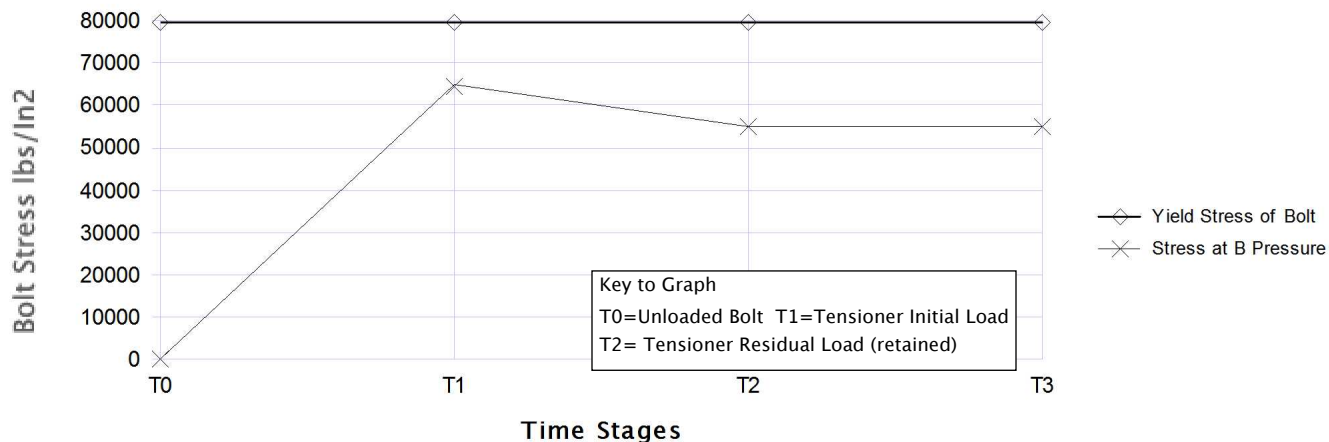

Max Detensioning Pressure refers to the maximum capacity of the tensioning tool and should not be considered to be the safe max load capacity of the flange
 100% Tensioning is the recommended mode of bolt tensioning, wherever possible use 100% Bolt to tool ratio
 Tentec Limited do not accept any liability for errors within or caused by the use of this software.